



...eine starke Verbindung

## YDEEVNEDEKLARATION

DoP Nr.: **MKT-1.2-201\_da**

- ✧ **Varetypens unikke identifikationskode:** **MKT bolt anker B A4 og B HCR**
- ✧ **Tilsligtet anvendelse:** Spoler til forankring i beton til overflødige ikke-bærende systeme, se bilag / Annex B
- ✧ **Fabrikant:** MKT Metall-Kunststoff-Technik GmbH & Co.KG  
Auf dem Immel 2  
67685 Weilerbach
- ✧ **System eller systemer til vurdering og kontrol af konstansen af ydeevnen:** 2+
- ✧ **Europæisk vurderingsdokument:** **EAD 330747-00-0601**  
Europæisk teknisk vurdering: **ETA-06/0155, 02.05.2022**  
Teknisk vurderingsorgan: DIBt, Berlin  
Notificeret organ/notificerede organer: NB 2873 – Technische Universität Darmstadt
- ✧ **Deklareret ydeevne/deklarerede ydeevner:**

Væsentlige funktioner	Ydeevne
<b>Brandsikring (BWR 2)</b>	
Brandegenskaber	Klasse A1
Brandsikkerhed	Bilag / Annex C1
<b>Sikkerhed under brug (BWR 4)</b>	
Karakteristisk modstand for alle belastningsretninger og alle fejltilstande til den forenkede designmetode	Bilag / Annex C1
Holdbarhed	Bilag / Annex B1

Ydeevnen for den vare, der er anført ovenfor, er i overensstemmelse med den deklarerede ydeevne. Denne ydeevnedeklaration er udarbejdet i overensstemmelse med forordning (EU) nr. 305/2011 på eneansvar af den fabrikant, der er anført ovenfor.

Underskrevet for fabrikanten og på dennes vegne af:

**Stefan Weustenhagen**  
(CEO)  
**Weilerbach, 02.05.2022**

p.p.

**Dipl.-Ing. Detlef Bigalke**  
(Leder af produktudvikling)



Originalen af denne erklæringserklæring blev skrevet på tysk. I tilfælde af afvigelser i oversættelsen er den tyske udgave gyldig.

## Specifications of intended use

<b>Multiple use for non-structural applications according to EN 1992-4:2018</b>		
<b>Wedge Anchor B A4 / B HCR</b>	<b>30 M6</b>	<b>40 M6</b>
Stainless steel A4		✓
High corrosion resistant steel HCR		✓
Static and quasi-static actions		✓
Fire exposure		✓
Cracked and uncracked concrete		✓

### Base materials:

- Reinforced or unreinforced normal weight concrete without fibres according to EN 206:2013 + A1:2016
- Strength classes C20/25 to C50/60 according to EN 206:2013 + A1:2016

### Use conditions (Environmental conditions):

- Structures subject to dry internal conditions (all materials)
- For all other conditions:

<b>Anchor version</b>	<b>Use according to EN 1993-1-4:2015 corresponding to the corrosion resistance class CRC according to Annex A, Table A.2</b>
B A4	CRC III
B HCR	CRC V

### Design:

- Anchorages are designed under the responsibility of an engineer experienced in anchorages and concrete work.
- Verifiable calculation notes and drawings are prepared taking account of the loads to be anchored. The position of the anchor is indicated on the design drawings (e.g. position of the anchor relative to reinforcement or to supports, etc.).
- Anchorages are designed according to EN 1992-4:2018 (and EOTA Technical Report TR 055:2018), design method B

### Installation:

- Hole drilling by hammer drill bit or vacuum drill bit.
- Anchor installation such that the effective anchorage depth is complied with. This compliance is ensured, if the thickness of fixture is not greater than the maximum thickness of fixture marked on the anchor in accordance with Annex A2 and the hexagon nut is placed at the end of the conical bolt as delivered by the manufacturer.
- Use of the fastener only as supplied by the manufacturer without exchanging the components of the fastener.

<b>MKT Wedge anchor B A4 and B HCR</b>	<b>Annex B1</b>
<b>Intended use Specifications</b>	

**Table B1: Installation parameters**

Anchor size		30 M6	40 M6
Nominal drill hole diameter	$d_0 =$ [mm]	6	6
Cutting diameter of drill bit	$d_{cut} \leq$ [mm]	6,40	6,40
Installation torque	$T_{inst} =$ [Nm]	8	8
Depth of drill hole	$h_1 \geq$ [mm]	45	55
Effective embedment depth	$h_{ef} \geq$ [mm]	30	40
Minimum thickness of concrete member	$h_{min}$ [mm]	80	80
Minimum spacing	$s_{min}$ [mm]	50	50
Minimum edge distance	$c_{min}$ [mm]	50	50
Diameter of clearance hole in the fixture	$d_f \leq$ [mm]	7	7

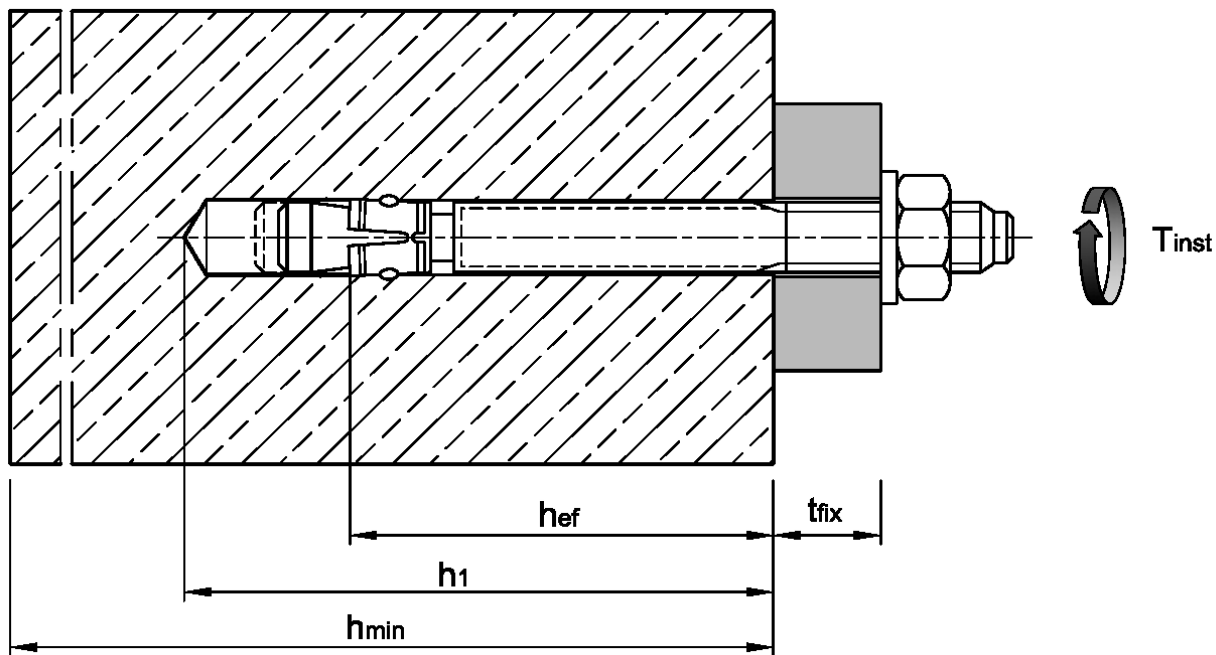

**MKT Wedge anchor B A4 and B HCR**

**Intended use**  
Installation parameters

**Annex B2**

## Installation instructions

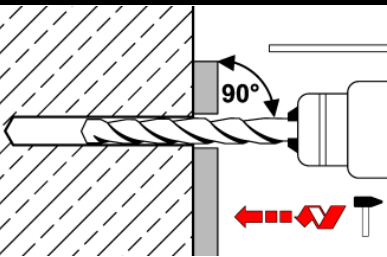
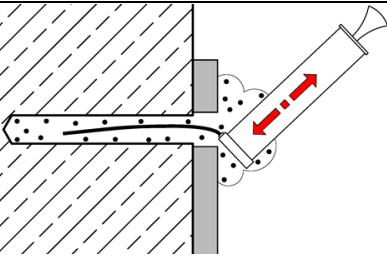
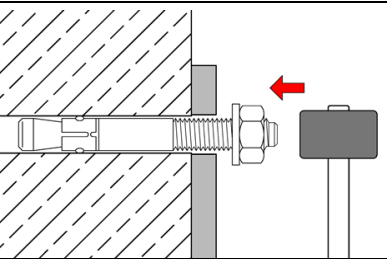
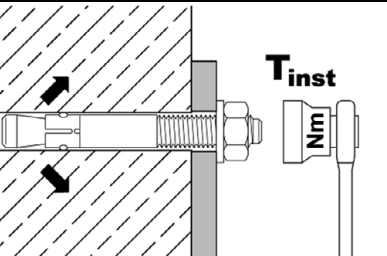
1		<p>Drill hole perpendicular to concrete surface. If using a vacuum drill bit, proceed with step 3.</p>
2		<p>Blow out dust. Alternatively, vacuum clean down to the bottom of the hole.</p>
3		<p>Drive in anchor. Observe effective anchorage depth. This is ensured, if the thickness of fixture is not greater than the maximum thickness of fixture marked on the anchor (according to Annex A2).</p>
4		<p>Apply installation torque <math>T_{inst}</math> by using torque wrench.</p>

MKT Wedge anchor B A4 and B HCR

Intended use  
Installation instructions

Annex B3

**Table C1: Characteristic values of resistance, design method B**

Anchor size			30 M6	40 M6
<b>All load directions</b>				
Characteristic resistance in C20/25 to C50/60	$F_{Rk}^0$	[kN]	5	6
Partial factor <sup>1)</sup>	$\gamma_M$	[-]	2,16	1,8
Design resistance in C20/25 to C50/60	$F_{Rd}^0$	[kN]	2,3	3,3
Spacing	$s_{cr}$	[mm]	260	370
Edge distance	$c_{cr}$	[mm]	130	185
<b>Shear load with lever arm</b>				
Characteristic bending resistance	$M_{Rk,s}^0$	[Nm]	10	10
Partial factor <sup>1)</sup>	$\gamma_{Ms}$	[-]	1,25	1,25

<sup>1)</sup> in absence of other national regulations

**Table C2: Characteristic values under fire exposure in concrete C20/25 to C50/60, design method B**

Anchor size			30 M6 40 M6
<b>Fire resistance class</b>	<b>In any load direction</b>		
R 30	Characteristic resistance	$F_{Rk,fi30}^0$	[kN] 0,6
	Characteristic bending resistance	$M_{Rk,s,fi30}^0$	[Nm] 0,5
R 60	Characteristic resistance	$F_{Rk,fi60}^0$	[kN] 0,5
	Characteristic bending resistance	$M_{Rk,s,fi60}^0$	[Nm] 0,4
R 90	Characteristic resistance	$F_{Rk,fi90}^0$	[kN] 0,3
	Characteristic bending resistance	$M_{Rk,s,fi90}^0$	[Nm] 0,3
R 120	Characteristic resistance	$F_{Rk,fi120}^0$	[kN] 0,3
	Characteristic bending resistance	$M_{Rk,s,fi120}^0$	[Nm] 0,2
R 30 to R 120	Spacing	$s_{cr,fi}$	[mm] 4 $h_{ef}$
		$s_{min}$	[mm] 50
	Edge distance	$c_{cr,fi}$	[mm] 2 $h_{ef}$
		$c_{min}$	[mm] 50
	Partial factor	$\gamma_{M,fi}$	[-] 1,0
If the fire attacks from more than one side, the edge distance of the anchor shall be $\geq 300$ mm.			

**MKT Wedge anchor B A4 and B HCR**

**Performances**

Characteristic resistances under normal ambient temperature and fire exposure, design method B

**Annex C1**