



...eine starke Verbindung

## DÉCLARATION DES PERFORMANCES

DoP No MKT-151 - fr

- ✧ **Code d'identification unique du produit type:** **MKT Boulon d'ancrage B A4 et B HCR**
- ✧ **Usage(s) prévu(s):** À couple contrôlé chevilles en acier inoxydable dans les tailles 30 M6 et 40 M6 pour utilisation comme fixation multiple de systèmes non structurels dans le béton, voir l'annexe/Annex B
- ✧ **Fabricant:** MKT Metall-Kunststoff-Technik GmbH & Co.KG  
Auf dem Immel 2  
67685 Weilerbach
- ✧ **Système(s) d'évaluation et de vérification de la constance des performances::** 2+
- ✧ **Document d'évaluation européen:** **ETAG 001-6**  
Évaluation technique européenne: **ETA-06/0155, 09.05.2018**  
Organisme d'évaluation technique: DIBt, Berlin  
Organisme(s) notifié(s): NB 1343 – MPA, Darmstadt
- ✧ **Performance(s) déclarée(s):**

Caractéristiques essentielles	Performances
<b>Sécurité en cas d'incendie (BWR2)</b>	
Le comportement du feu	Classe A1
Résistance au feu	Annexe/Annex C1
<b>Sécurité lors de l'utilisation (BWR4)</b>	
Valeurs caractéristiques pour toutes les directions de charge	Annexe/Annex C1

Les performances du produit identifié ci-dessus sont conformes aux performances déclarées. Conformément au règlement (UE) no 305/2011, la présente déclaration des performances est établie sous la seule responsabilité du fabricant mentionné ci-dessus.

Signé pour le fabricant et en son nom par:



**Stefan Weustenhagen**  
(Directeur général)  
**Weilerbach, 09.05.2018**

p.p.



**Dipl.-Ing. Detlef Bigalke**  
(Directeur du développement de produits)



L'original de cette déclaration d'exécution a été rédigé en allemand. En cas de divergences dans la traduction, la version allemande fait foi.

## Specifications of intended use

Multiple use for non-structural applications, according to ETAG 001 Part 6, Edition August 2010

### Anchorage subject to:

- static and quasi-static loads
- fire exposure

### Base materials:

- Reinforced or unreinforced normal weight concrete according to EN 206-1:2000
- Strength classes C20/25 to C50/60 according to EN 206-1:2000
- Cracked and uncracked concrete

### Use conditions (Environmental conditions):

- Structures subject to dry internal conditions (stainless steel or high corrosion resistant steel).
- Structures subject to external atmospheric exposure (including industrial and marine environment) and to permanently damp internal condition, if no particular aggressive conditions exist (stainless steel or high corrosion resistant steel).
- Structures subject to external atmospheric exposure and to permanently damp internal condition, if other particular aggressive conditions (high corrosion resistant steel).

Note: Particular aggressive conditions are e.g. permanent, alternating immersion in seawater or the splash zone of seawater, chloride atmosphere of indoor pools or atmosphere with extreme chemical pollution (e.g. in desulphurization plants or road tunnels where de-icing materials are used.)

### Design:

- Anchorages are designed under the responsibility of an engineer experienced in anchorages and concrete work.
- Verifiable calculation notes and drawings are prepared taking account of the loads to be anchored. The position of the anchor is indicated on the design drawings (e.g. position of the anchor relative to reinforcement or to supports, etc.).
- Anchorages under static or quasi-static actions for multiple use in non-structural applications are designed in accordance with:
  - ETAG 001, Annex C, design method B, Edition August 2010 or
  - CEN/TS 1992-4: 2009, design method B
- Anchorages under fire exposure are designed in accordance with:
  - ETAG 001, Annex C, design method B, Edition August 2010 and EOTA Technical Report TR 020, Edition May 2004 or
  - CEN/TS 1992-4: 2009, Annex D
  - It must be ensured that local spalling of the concrete cover does not occur.

### Installation:

- Anchor installation carried out by appropriately qualified personnel and under the supervision of the person responsible for technical matters of the site,
- Anchor installation in accordance with the manufacturer's specifications and drawings and using the appropriate tools,
- Positioning of the drill holes without damaging the reinforcement.
- Anchor installation such that the effective anchorage depth is complied with. This compliance is ensured, if the thickness of fixture is not greater than the maximum thickness of fixture marked on the anchor in accordance with Annex A2 and the hexagon nut is placed at the end of the conical bolt as delivered by the manufacturer.

## Wedge Anchor B A4 and B HCR

Intended use  
Specifications

Annex B1

**Table B1: Installation parameters**

Anchor size		30 M6	40 M6
Nominal drill hole diameter	$d_0 =$ [mm]	6	6
Cutting diameter of drill bit	$d_{cut} \leq$ [mm]	6,40	6,40
Tightening torque	$T_{inst} =$ [Nm]	8	8
Drill hole depth	$h_1 \geq$ [mm]	45	55
Effective embedment depth	$h_{ef} \geq$ [mm]	30	40
Minimum thickness of concrete member	$h_{min}$ [mm]	80	80
Minimum spacing	$s_{min}$ [mm]	50	50
Minimum edge distance	$c_{min}$ [mm]	50	50
Diameter of clearance hole in the fixture	$d_f \leq$ [mm]	7	7

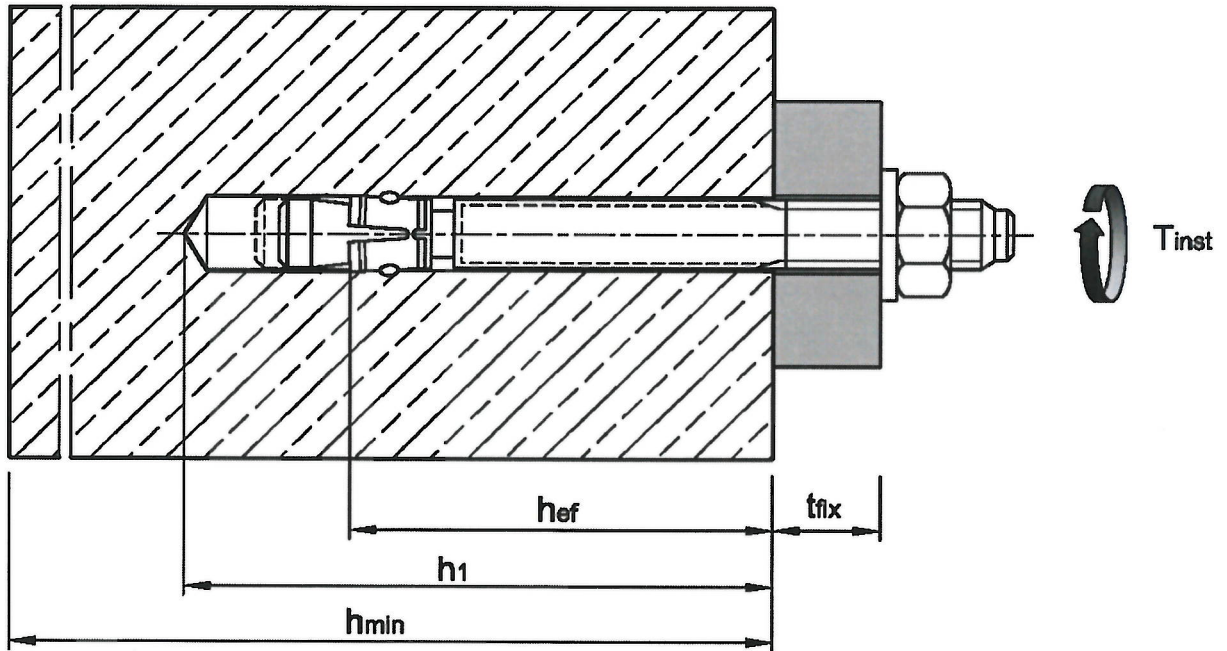

**Wedge Anchor B A4 and B HCR**

Intended use  
Installation parameters

**Annex B2**



## Installation instructions

	<p>Drill hole perpendicular to concrete surface, positioning of the drill holes without damaging the reinforcement.          In case of aborted hole: new drilling at a minimum distance away of twice the depth of the aborted hole or smaller distance if the aborted drill hole is filled with high strength mortar and if under shear or oblique tension load it is not in the direction of load application.</p>
	<p>Blow out dust.</p>
	<p>Check position of nut.</p>
	<p>Drive in anchor.          Observe effective anchorage depth. This is ensured, if the thickness of fixture is not greater than the maximum thickness of fixture marked on the anchor (acc. to Annex A2).</p>
	<p>Apply installation torque <math>T_{inst}</math> by using torque wrench.</p>

### Wedge Anchor B A4 and B HCR

Intended use  
 Installation Instructions

Annex B3

**Table C1: Characteristic values of resistance, design method B**

Anchor size			30 M6	40 M6
<b>All load directions</b>				
Characteristic resistance in C20/25 to C50/60	$F_{Rk}^0$	[kN]	5	6
Partial factor	$\gamma_M$	[-]	2,16	1,8
Design resistance in C20/25 to C50/60	$F_{Rd}^0$	[kN]	2,3	3,3
Spacing	$s_{cr}$	[mm]	260	370
Edge distance	$c_{cr}$	[mm]	130	185
<b>Shear load with lever arm</b>				
Characteristic bending resistance	$M_{Rk,s}^0$ <sup>1)</sup>	[Nm]	10	10
Partial factor	$\gamma_{Ms}$	[-]	1,25	1,25

<sup>1)</sup> Characteristic bending resistance  $M_{Rk,s}^0$  for equation (5.5) in ETAG 001, Annex C respectively equation (14) CEN/TS 1992-4-4

**Table C2: Characteristic values under fire exposure in concrete C20/25 to C50/60, design method B**

Anchor size			30 M6 40 M6
<b>Fire resistance class</b>	<b>In any load direction</b>		
R 30	Characteristic resistance	$F_{Rk,fi30}^0$	[kN] 0,6
	Characteristic bending resistance	$M_{Rk,s,fi30}^0$	[Nm] 0,5
R 60	Characteristic resistance	$F_{Rk,fi60}^0$	[kN] 0,5
	Characteristic bending resistance	$M_{Rk,s,fi60}^0$	[Nm] 0,4
R 90	Characteristic resistance	$F_{Rk,fi90}^0$	[kN] 0,3
	Characteristic bending resistance	$M_{Rk,s,fi90}^0$	[Nm] 0,3
R 120	Characteristic resistance	$F_{Rk,fi120}^0$	[kN] 0,3
	Characteristic bending resistance	$M_{Rk,s,fi120}^0$	[Nm] 0,2
R 30 to R 120	Spacing	$s_{cr,fi}$	[mm] 4 $h_{ef}$
		$s_{min}$	[mm] 50
	Edge distance	$c_{cr,fi}$	[mm] 2 $h_{ef}$
		$c_{min}$	[mm] 50
	Partial factor	$\gamma_{M,fi}$	[-] 1,0
If the fire attacks from more than one side, the edge distance shall be $\geq 300$ mm.			

**Wedge Anchor B A4 and B HCR**

**Performance**  
Characteristic resistances under normal ambient temperature and fire exposure, design method B

**Annex C1**