



... eine starke Verbindung

DECLARAÇÃO DE DESEMPENHO

DoP número: MKT-161 - pt

- ✧ **Código de identificação único do produto-tipo:** Âncora de carga pesada SLZ
- ✧ **Utilização(ões) prevista(s):** Cavilha em expansão (aço galvanizado) no tamanho 14 / M10 para ancoragem no concreto, ver Anexo B / Annex B
- ✧ **Fabricante:** MKT Metall-Kunststoff-Technik GmbH & Co.KG
Auf dem Immel 2
67685 Weilerbach
- ✧ **Sistemas de avaliação e verificação da regularidade:** 1
- ✧ **Documento de Avaliação Europeu** EAD 330232-00-0601
Avaliação Técnica Europeia : ETA-09/0342, 01.03.2018
Organismo de Avaliação Técnica: DIBt, Berlin
Organismo(s) notificado (s): NB 1343 – MPA, Darmstadt

✧ **Desempenho(s) declarado(s):**

Características essenciais	Desempenho
Resistência mecânica e estabilidade (BWR 1)	
Resistências características (efeitos estáticos e quase-estáticos), Deslocamentos	Anexo / Annex C1 – C2
Segurança contra incêndio (BWR 2)	
Comportamento do fogo	Classe A1
Resistência ao fogo	Anexo / Annex C3

O desempenho do produto identificado acima está em conformidade com o conjunto de desempenhos declarados. A presente declaração de desempenho é emitida, em conformidade com o Regulamento (EU) n.º 305/2011, sob a exclusiva responsabilidade do fabricante identificado acima.

Assinado por e em nome do fabricante por:

Stefan Weustenhagen
(Diretor-gerente)
Weilerbach, 01.03.2018

p.p. 
Dipl.-Ing. Detlef Bigalke
(Director de Desenvolvimento de Produto)



O original desta declaração de desempenho foi escrito em alemão. Em caso de desvios na tradução, a versão alemã é válida.

Specifications of intended use

Anchorage subject to:

- Static or quasi-static action
- fire exposure

Base materials:

- Reinforced or unreinforced normal weight concrete according to EN 206-1:2000
- Strength classes C20/25 to C50/60 according to EN 206-1:2000
- Cracked and uncracked concrete

Use conditions (Environmental conditions):

- Structures subject to dry internal conditions (zinc plated steel).

Design:

- Anchorages are designed under the responsibility of an engineer experienced in anchorages and concrete work.
- Verifiable calculation notes and drawings are prepared taking account of the loads to be anchored. The position of the anchor is indicated on the design drawings (e.g. position of the anchor relative to reinforcement or to supports, etc.).
- Anchorages are designed according to FprEN 1992-4: 2016 and TR 055.

Installation:

- Anchor installation carried out by appropriately qualified personnel and under the supervision of the person responsible for technical matters of the site.
- Positioning of the drill holes without damaging the reinforcement
- In case of aborted hole: new drilling at a minimum distance away of twice the depth of the aborted hole or smaller distance if the aborted drill hole is filled with high strength mortar and if under shear or oblique tension load it is not in the direction of load application.
- Anchor installation such that the effective anchorage depth is complied with. This compliance is ensured, when the embedment mark of the anchor does no more exceed the concrete surface
- Drilling by hammer drill bit (use of vacuum drill bit is admissible)

Highload Anchor SLZ

Intended use
Specifications

Annex B1

Installation instructions

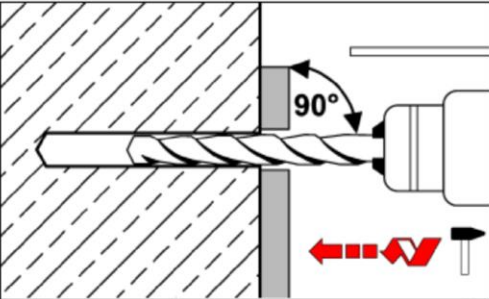
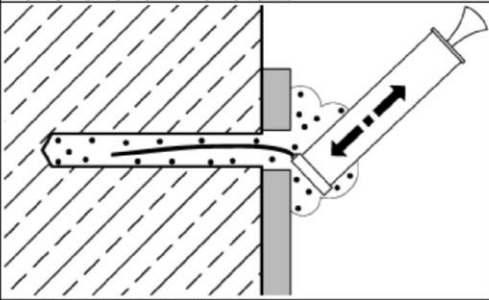
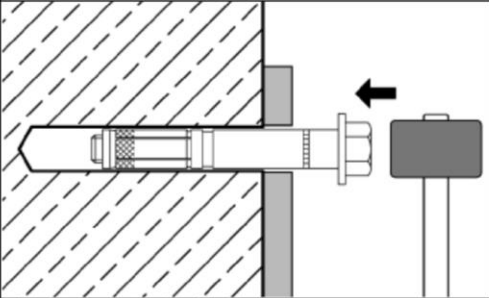
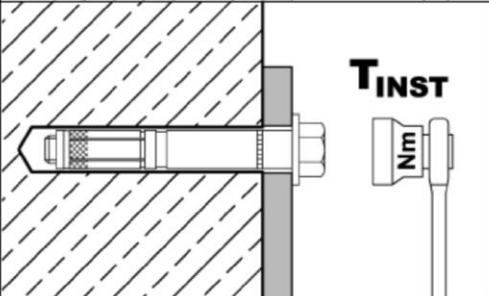
1		Drill hole perpendicular to concrete surface. Using a vacuum drill bit, proceed with step 3.
2		Blow out dust. Alternatively vacuum clean down to the bottom of the hole.
3		Drive in anchor.
4		Apply tightening torque T_{inst} by using torque wrench.

Highload Anchor SLZ

Intended use
Installation instructions

Annex B2

Table B1: Installation parameters

Anchor size			14/M10
Size of thread			M10
Effective anchorage depth	h_{ef}	[mm]	65
Nominal diameter of drill bit	d_0	[mm]	14
Cutting diameter of drill bit	$d_{cut} \leq$	[mm]	14,5
Depth of drill hole	$h_1 \geq$	[mm]	85
Diameter of clearance hole in the fixture mounted on distance sleeve	$d_f \leq$	[mm]	16
Diameter of clearance hole in the fixture mounted on threaded bolt	$d_f \leq$	[mm]	12
Installation torque	T_{inst}	[Nm]	50
Minimum thickness of member	h_{min}	[mm]	130
Minimum spacing	s_{min}	[mm]	60
	$c \geq$	[mm]	120
Minimum edge distance	c_{min}	[mm]	70
	$s \geq$	[mm]	130

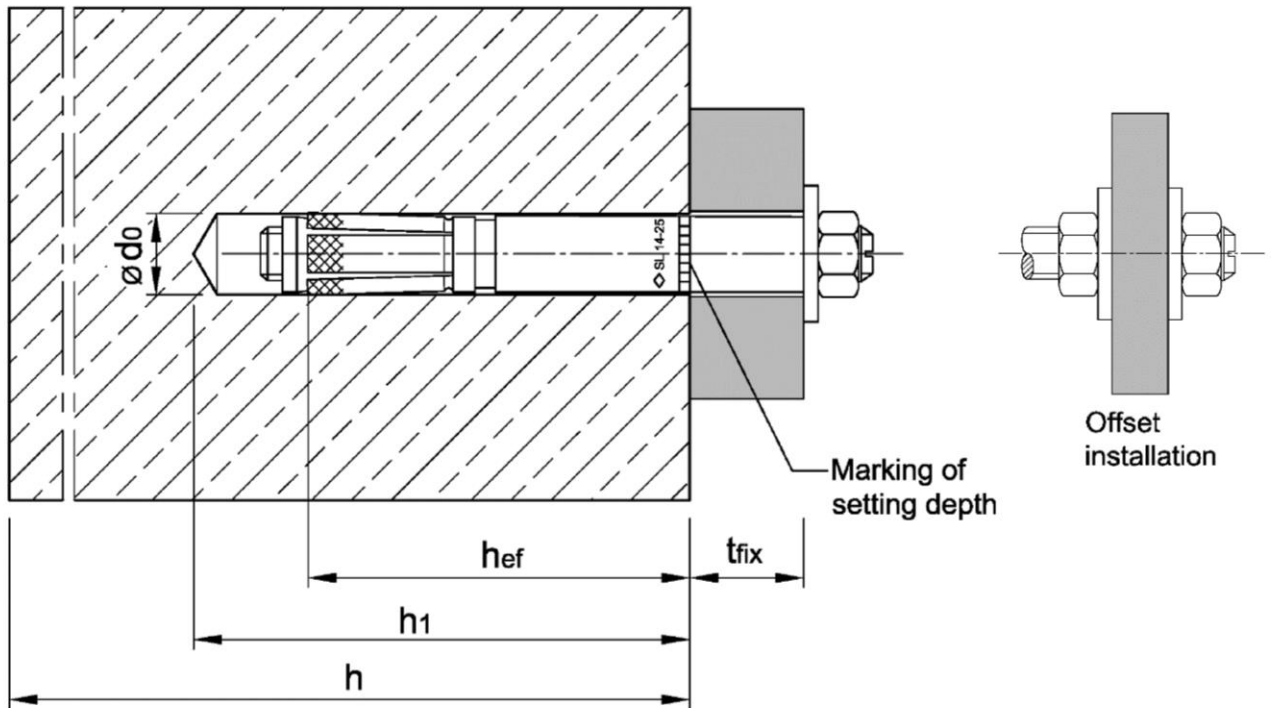

Highload Anchor SLZ

Intended use
Installation parameters

Annex B3

Table C1: Characteristic values for tension loads

Anchor size			14/M10
Installation safety factor	γ_{inst}	[-]	1,0
Steel failure			
Characteristic resistance	$N_{RK,s}$	[kN]	46
Partial safety factor	γ_{Ms}	[-]	1,5
Pull-out failure			
Characteristic resistance in cracked concrete C20/25	$N_{RK,p}$	[kN]	12
Characteristic resistance in uncracked concrete C20/25	$N_{RK,p}$	[kN]	20
Increasing factors for $N_{RK,p}$	ψ_C	[-]	$\left(\frac{f_{ck}}{20}\right)^{0,5}$
Concrete cone failure			
Effective Anchorage depth	h_{ef}	[mm]	65
Spacing	$s_{cr,N}$	[mm]	3 h_{ef}
Edge distance	$c_{cr,N}$	[mm]	1,5 h_{ef}
Factor k_1 for cracked concrete	$k_{cr,N}$	[-]	7,7
Factor k_1 for uncracked concrete	$k_{ucr,N}$	[-]	11,0
Splitting failure			
Characteristic resistance in uncracked concrete	$N^0_{RK,sp}$	[kN]	min [$N_{RK,p}; N^0_{RK,c}$]
Spacing	$s_{cr,sp}$	[mm]	390
Edge distance	$c_{cr,sp}$	[mm]	195

Table C2: Displacements under tension loads

Anchor size			14/M10
Tension load in cracked concrete	N	[kN]	5,7
Displacement	δ_{N0}	[mm]	0,8
	$\delta_{N\infty}$	[mm]	1,5
Tension load in uncracked concrete	N	[kN]	9,5
Displacement	δ_{N0}	[mm]	0,3
	$\delta_{N\infty}$	[mm]	1,2

Highload Anchor SLZ

Performance
 Characteristic values and displacements under **tension load**

Annex C1

Table C3: Characteristic values for shear loads

Anchor size			14/M10
Steel failure without lever arm			
Characteristic resistance, fixture mounted on distance sleeve with $t_{fix} \leq 75$ mm	$V^0_{RK,s}$	[kN]	32,8
Characteristic resistance, fixture mounted on distance sleeve with $t_{fix} > 75$ mm	$V^0_{RK,s}$	[kN]	23,2
Factor	k_7	[-]	1,0
Partial safety factor	γ_{Ms}	[-]	1,25
Steel failure with lever arm			
Characteristic resistance	$M^0_{RK,s}$	[Nm]	60
Partial safety factor	γ_{Ms}	[-]	1,25
Concrete pry-out failure			
Factor	k_8	[-]	2,0
Concrete edge failure			
Effective length of anchor in shear loading	l_f	[mm]	65
Outside diameter of anchor	d_{nom}	[mm]	14

Table C4: Displacements under shear loads

Anchor size			14/M10
Shear load in non-cracked concrete	V	[kN]	13,2
Displacement	δ_{V0}	[mm]	2,2
	$\delta_{V\infty}$	[mm]	3,3

Highload Anchor SLZ

Performance
 Characteristic values and displacements under **shear load**

Annex C2

Table C5: Characteristic values under fire exposure in concrete C20/25 to C50/60

Anchor size			14/M10	
Tension load				
Steel failure				
Characteristic resistance	R30	$N_{Rk,s,fi}$	[kN]	0,9
	R60			0,8
	R90			0,6
	R120			0,5
Shear load				
Steel failure without lever arm				
Characteristic resistance	R30	$V_{Rk,s,fi}$	[kN]	0,9
	R60			0,8
	R90			0,6
	R120			0,5
Steel failure with lever arm				
Characteristic resistance	R30	$M^0_{Rk,s,fi}$	[Nm]	1,1
	R60			1,0
	R90			0,7
	R120			0,6

Highload Anchor SLZ

Performance
Characteristic values under **fire exposure**

Annex C3